

FDH16A

© ASSEMBLE WITH JOINT IN THE SHELL TOWARDS THE TOP OF THE MOUNTING TO GET PROPER ALIGNMENT FIT.

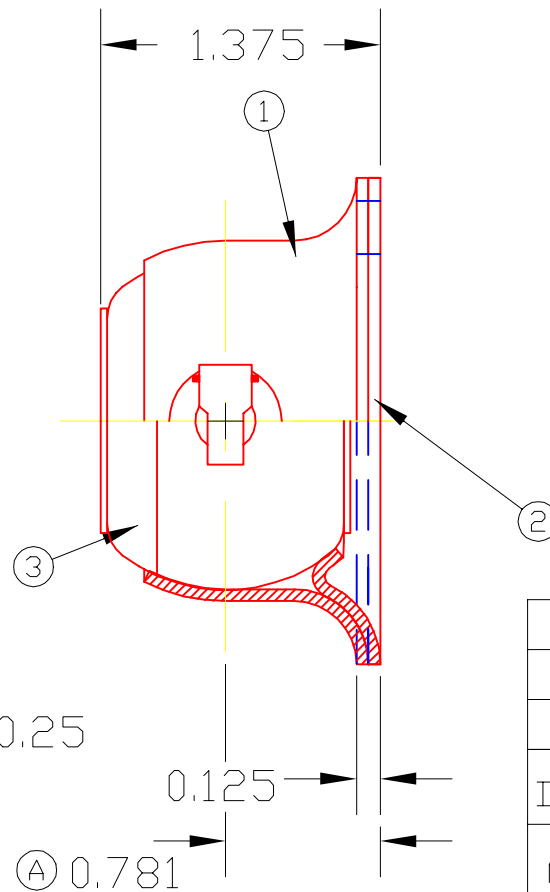
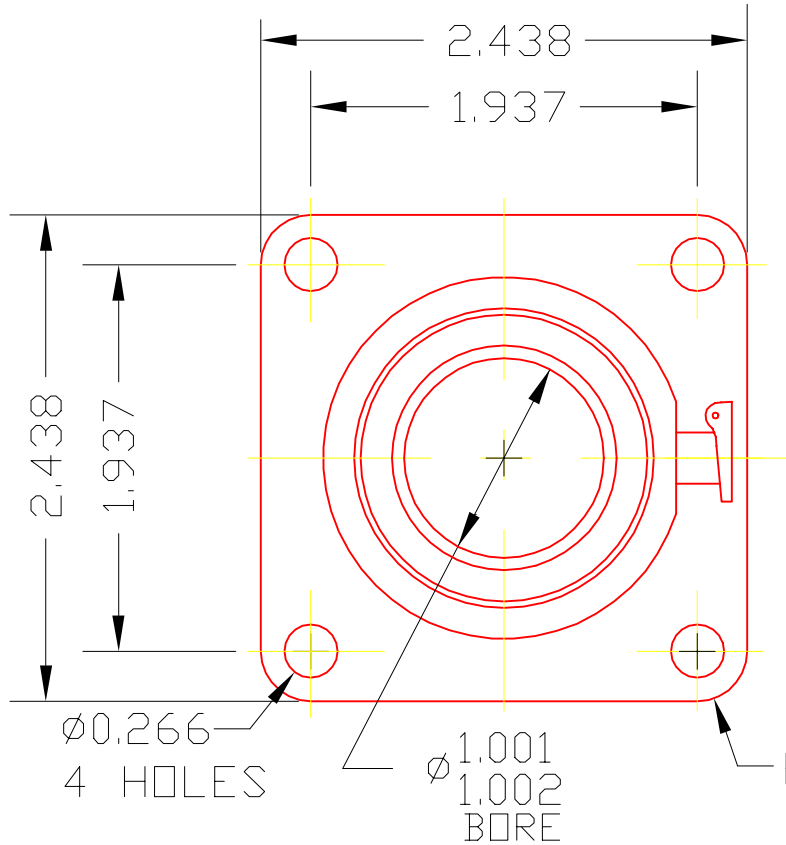

3	H16A	BRG. BALL	1
2	1641	BACK PLATE	1
1	1640	CONTAINER	1
DET	PART NUMBER	DESCRIPTION	AMT

△ TRIANGLE MANUFACTURING CO.  
OSHKOSH, WI.

NAME FLANGE PILLOW BLOCK

USED IN FD-SERIES

DATE 5-17-61 PART NO.

DRAWN BW-88

CHECKED SP

SCALE 1 / 1

FDH16A

LUB.	OIL T.M.C. #L-1
PLATING	GALV
MATERIAL	SEE DETAILS
ALL DIMS. $\pm 0.020$ UNLESS OTHERWISE SPECIFIED	

CHANGE LEVEL
C 07-13-94