

HA4106P

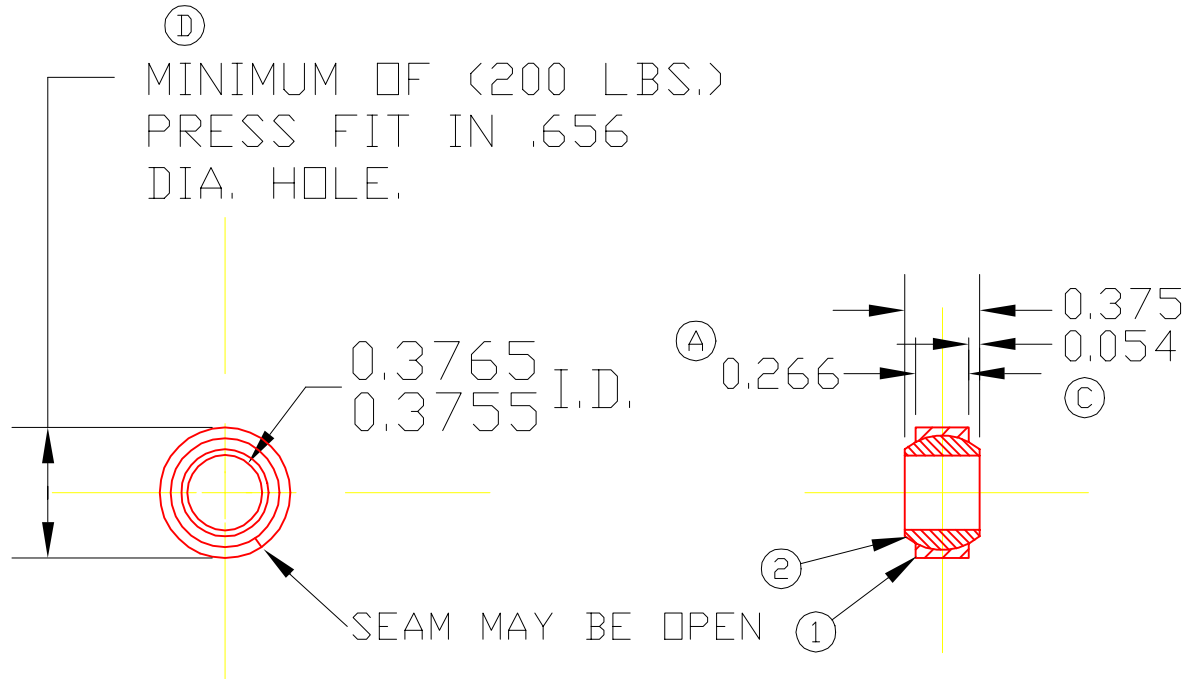

STAMPED WITH TRIANGLE NAME STAMP

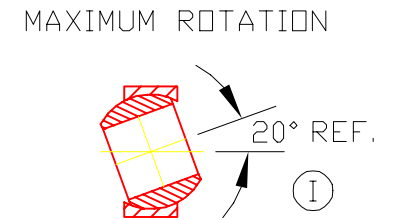

CUSTOMER REFERENCE NOTE: The recommended tolerance for the diameter of the mounting hole into which the ball bushing is pressed is +0.000", -0.001". The press fit will increase with a decrease in hole diameter. Freedom of movement of the spherical bushing in its retainer may decrease as the press fit increases. ⑤

⑥	2	6093	RETAINER	1
	1	4106P	BRG. BALL	1
DET	PART NUMBER	DESCRIPTION	AMT	

△ TRIANGLE MANUFACTURING CO.
OSHKOSH, WI.

NAME BALL & RET. ASS'Y

USED IN HA SERIES

DATE 7-24-78 PART NO.

DRAWN LML

CHECKED SP

SCALE 1 / 1

HA4106P

⑦	FIT LIGHT DRAG - SNUG
	PLATING ////
	MATERIAL SEE DETAILS
	ALL DIMS ±.02 UNLESS SPECIFIED

CHANGE LEVEL
J 12-02-03