

HB1106P

MINIMUM OF (200 LBS.)
PRESS FIT IN .875
DIA. HOLE.

SEAM MAY BE OPEN

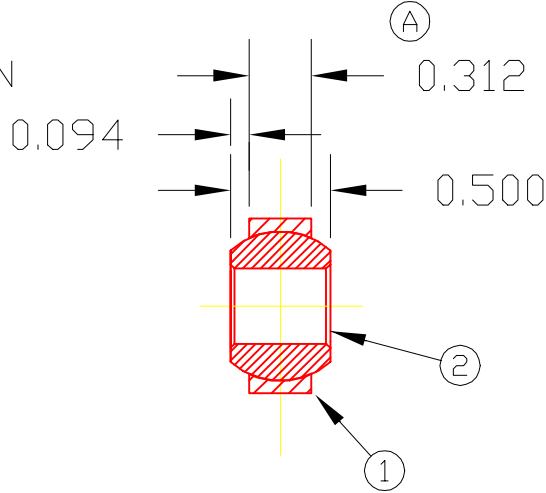
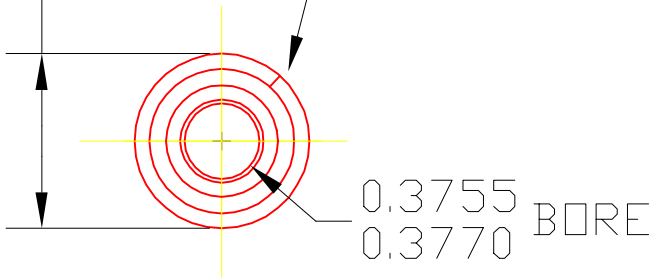

MAXIMUM ROTATION

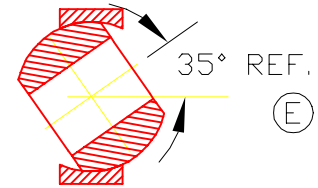

STAMPED WITH TRIANGLE
NAME STAMP

CUSTOMER REFERENCE NOTE: The recommended tolerance for the diameter of the mounting hole into which the ball bushing (F) is pressed is +0.000", -0.001". The press fit will increase with a decrease in hole diameter. Freedom of movement of the spherical bushing in its retainer may decrease as the press fit increases.

2	3453	RETAINER	1
1	1106P	BRG. BALL	1
DET	PART NUMBER	DESCRIPTION	AMT

▲ TRIANGLE MANUFACTURING CO.
OSHKOSH, WI.

NAME BALL & RET. ASS'Y

USED IN HB SERIES

DATE 10-23-68 PART NO.

DRAWN SP

CHECKED SP

SCALE 1 / 1

HB1106P

(B)

FIT	LIGHT DRAG - SNUG
PLATING	ELECTRO ZINC
MATERIAL	SEE DETAILS
ALL DIMS ±.02 UNLESS SPECIFIED	

CHANGE LEVEL
F 12-08-03