

HB1108P

MINIMUM OF (200 LBS.)
PRESS FIT IN .875
DIA. HOLE.

CUSTOMER REFERENCE NOTE: The recommended tolerance for the diameter of the mounting hole into which the ball bushing is pressed is $+0.000", -0.001"$. The press fit will increase with a decrease in hole diameter. Freedom of movement of the spherical bushing in it's retainer may decrease as the press fit increases.

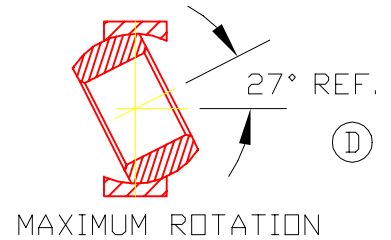
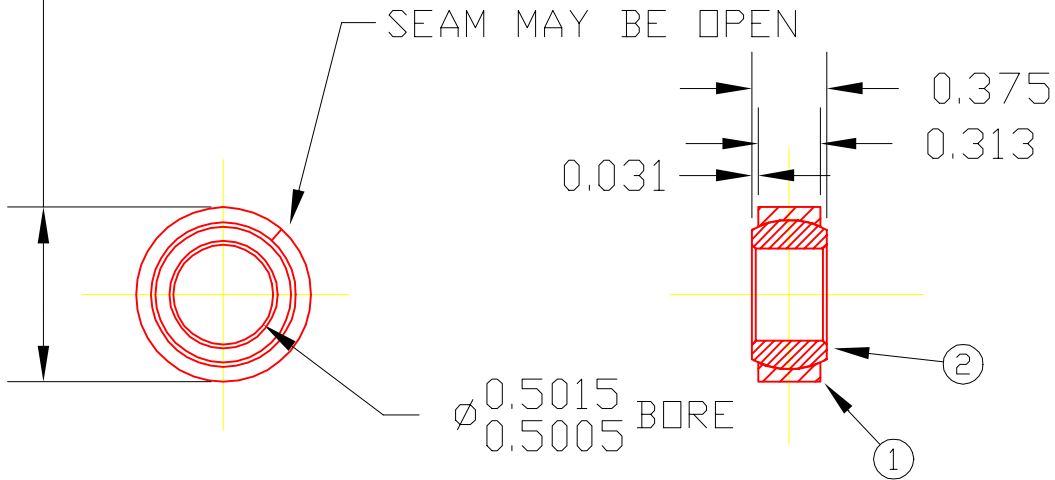

STAMPED WITH TRIANGLE
NAME STAMP

2	3453	RETAINER	1
1	1108P	BRG. BALL	1
DET	PART NUMBER	DESCRIPTION	AMT
A TRIANGLE MANUFACTURING CO. OSHKOSH, WI.			
NAME BALL & RET. ASS'Y			
USED IN HB SERIES			
DATE 9-1-75		PART NO.	
DRAWN LML		HB1108P	
CHECKED SP			
SCALE 1 / 1			

⑤	FIT LIGHT DRAG - SNUG
PLATING	ELECTRO ZINC
MATERIAL	SEE DETAILS
ALL DIMS ± 0.02 UNLESS SPECIFIED	

CHANGE LEVEL
E 12-02-03