

# HB1205P

STAMPED WITH TRIANGLE  
NAME STAMP

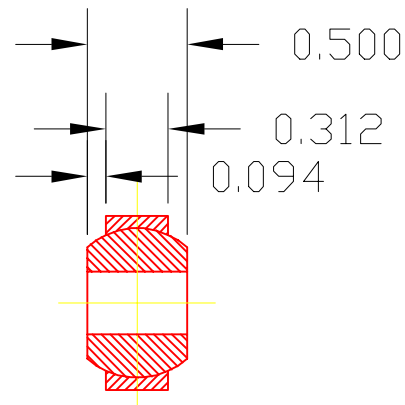

MAXIMUM ROTATION

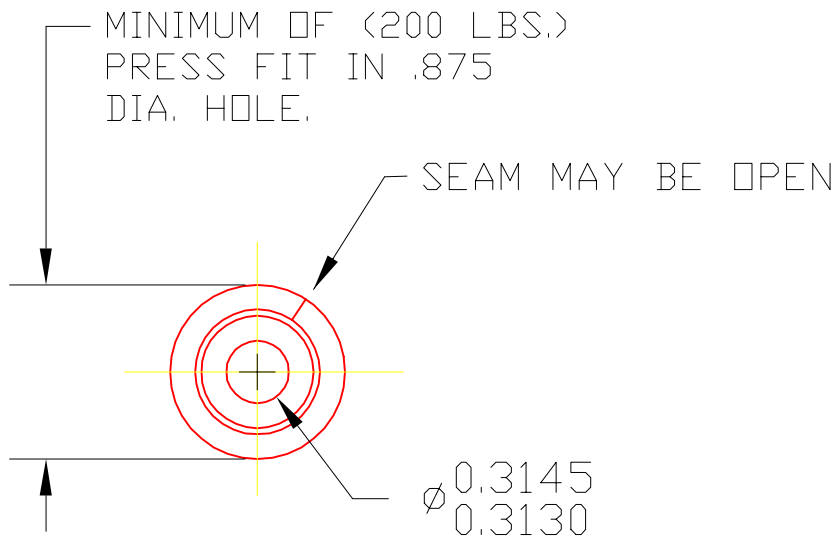
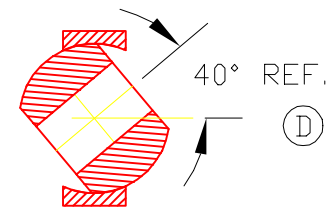

CUSTOMER REFERENCE NOTE: The recommended tolerance for the diameter of the mounting hole into which the ball bushing is pressed is +0.000", -0.001". The press fit will increase with a decrease in hole diameter. Freedom of movement of the spherical bushing in its retainer may decrease as the press fit increases. (E)

2	3453	RETAINER	1
1	1205P	BRG. BALL	1
DET	PART NUMBER	DESCRIPTION	AMT

TRIANGLE MANUFACTURING CO.  
OSHKOSH, WI.

NAME BALL & RET. ASS'Y

USED IN HB SERIES

DATE 2-12-67

PART NO.

DRAWN LML

CHECKED SP

SCALE 1 / 1

HB1205P

(A)

FIT LIGHT DRAG - SNUG

PLATING ////

MATERIAL SEE DETAILS

ALL DIMS ±.020 UNLESS SPECIFIED

CHANGE LEVEL	
E	12-08-03