

HB1206P

STAMPED WITH TRIANGLE
NAME STAMP

MINIMUM OF (200 LBS.)
PRESS FIT IN .875
DIA. HOLE.

SEAM MAY BE OPEN

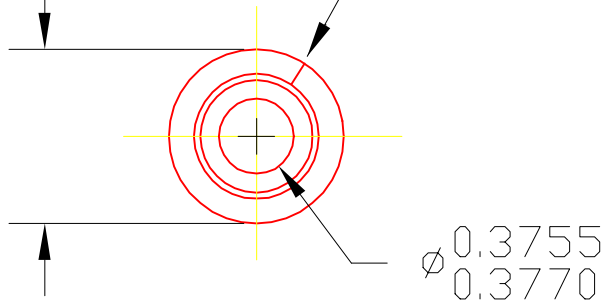

CUSTOMER REFERENCE NOTE: The recommended tolerance for the diameter of the mounting hole into which the ball bushing is pressed is +0.000", -0.001". The press fit will increase with a decrease in hole diameter. Freedom of movement of the spherical bushing in it's retainer may decrease as the press fit increases. (E)

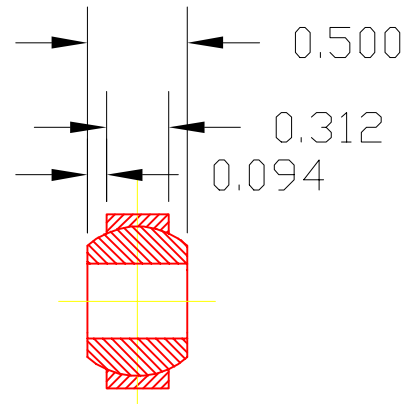

MAXIMUM ROTATION

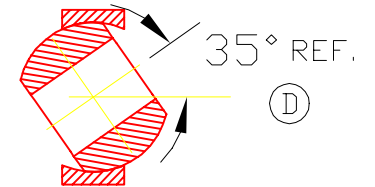

2	3453	RETAINER	1
1	1206P	BRG. BALL	1
DET	PART NUMBER	DESCRIPTION	AMT

TRIANGLE MANUFACTURING CO.
OSHKOSH, WI.

NAME BALL & RET. ASS'Y

USED IN HB SERIES

DATE 12-14-71

PART NO.

DRAWN LML

CHECKED SP

SCALE 1 / 1

HB1206P

(A)

FIT	LIGHT DRAG - SNUG
PLATING	////
MATERIAL	SEE DETAILS
ALL DIMS ±.020 UNLESS SPECIFIED	

CHANGE LEVEL
E 12-08-03