

HC3908P

CUSTOMER REFERENCE NOTE: The recommended tolerance for the diameter of the mounting hole into which the ball bushing (F) is pressed is +0.000", -0.001". The press fit will increase with a decrease in hole diameter. Freedom of movement of the spherical bushing in it's retainer may decrease as the press fit increases.

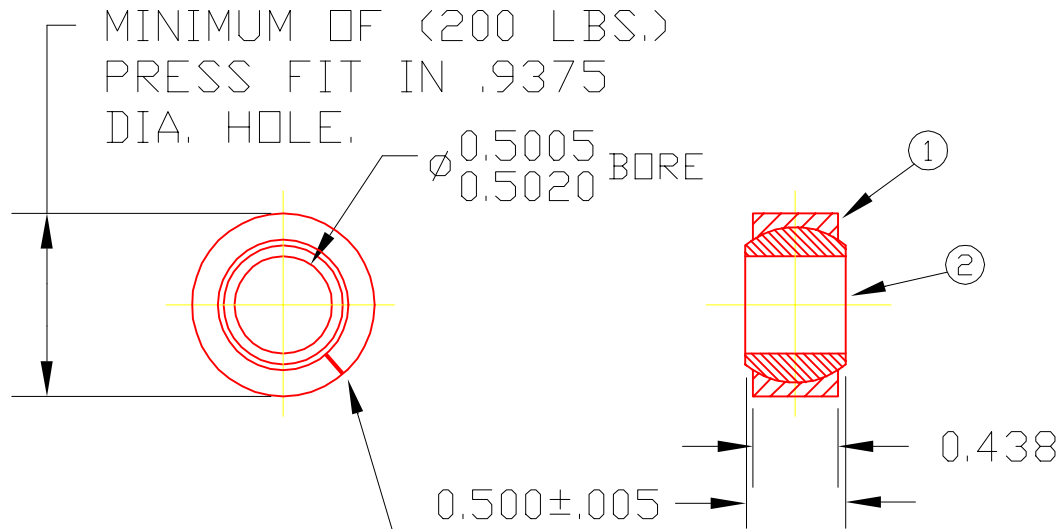

MAXIMUM ROTATION

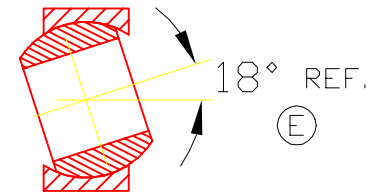

SIZED TO CUST. FIT REQUEST (B)

STAMPED WITH TRIANGLE NAME STAMP

2	3908P	BRG. BALL	1
1	3770	RETAINER	1
DET	PART NUMBER	DESCRIPTION	AMT

▲ TRIANGLE MANUFACTURING CO.
OSHKOSH, WI.

NAME BALL & RET. ASS'Y

USED IN // // //

DATE 7-25-66

PART NO.

DRAWN LML

CHECKED SP

SCALE 1 / 1

HC3908P

CHANGE LEVEL	
F	12-08-03

LUB.	OIL
FIT	LIGHT DRAG - SNUG
PLATING	ELECTRO ZINC
MATERIAL	SEE DETAILS
ALL DIMS ±.02 UNLESS SPECIFIED	