

HE1510P

STAMPED WITH TRIANGLE
NAME STAMP

CUSTOMER REFERENCE NOTE: The recommended tolerance for the diameter of the mounting hole into which the ball bushing (E) is pressed is +0.000", -0.001". The press fit will increase with a decrease in hole diameter. Freedom of movement of the spherical bushing in it's retainer may decrease as the press fit increases.

SEAM MAY BE OPEN

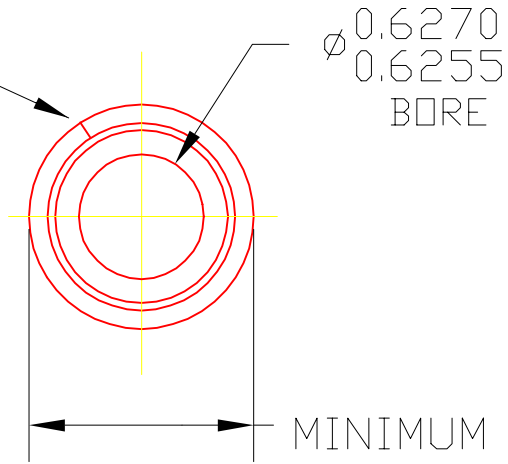

∅ 0.6270
0.6255
BORE

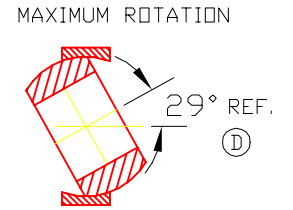
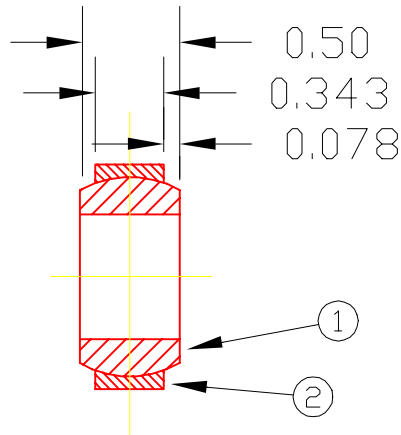

MINIMUM OF (200 LBS.)
PRESS FIT IN 1.125
DIA. HOLE.

2	1510P	BRG. BALL	1
1	4014	RETAINER	1
DET	PART NUMBER	DESCRIPTION	AMT

▲ TRIANGLE MANUFACTURING CO.
OSHKOSH, WI.

NAME BALL & RET. ASS'Y

USED IN HE SERIES

DATE 7-13-71

PART NO.

DRAWN SP

CHECKED SP

SCALE 1 / 1

HE1510P

(A) (B)

FIT LIGHT DRAG - SNUG

PLATING ELECTRO-ZINC

MATERIAL SEE DETAILS

ALL DIMS ±.02 UNLESS SPECIFIED

CHANGE LEVEL

E 12-11-03