

SEAM MAY BE OPEN

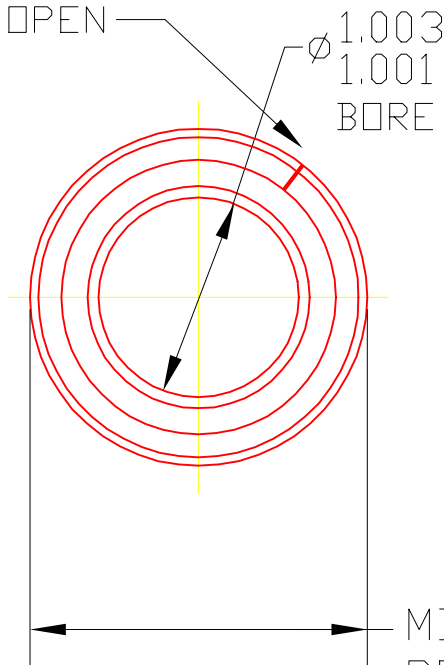

MINIMUM OF (200 LBS.)
PRESS FIT IN 1.6875
DIA. HOLE.

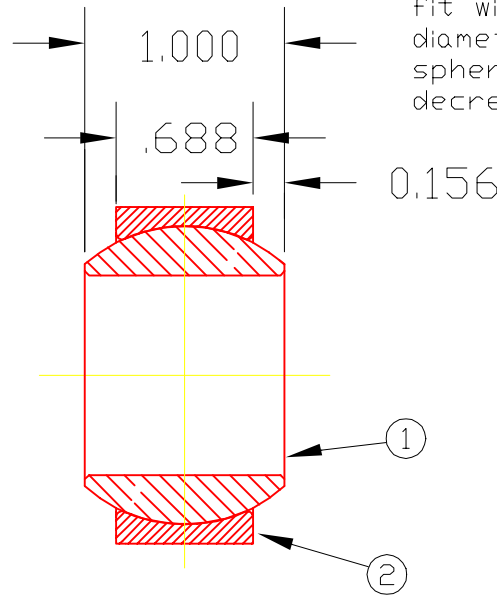

CUSTOMER REFERENCE NOTE: The recommended tolerance for the diameter of the mounting hole into which the ball bushing (F) is pressed is +0.000", -0.001". The press fit will increase with a decrease in hole diameter. Freedom of movement of the spherical bushing in it's retainer may decrease as the press fit increases.

MAXIMUM ROTATION

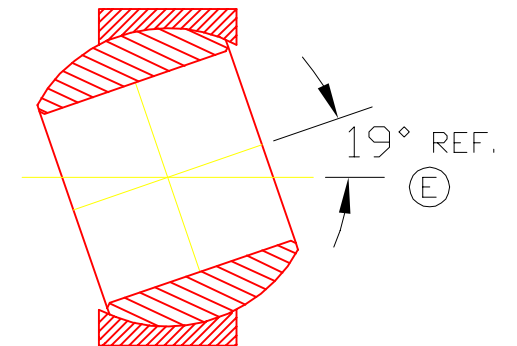

2	4016P	BRG. BALL	1
1	4012	RETAINER	1
DET	PART NUMBER	DESCRIPTION	AMT

△ TRIANGLE MANUFACTURING CO.
OSHKOSH, WI.

NAME BALL & RET. ASS'Y

USED IN HF SERIES

DATE 9-17-68

PART NO.

DRAWN LML

CHECKED SP

SCALE 1 / 1

HF 4016P

(A)(B) FIT LIGHT DRAG - SNUG

PLATING ELECTRO ZINC

MATERIAL SEE DETAILS

ALL DIMS. ±.020 UNLESS OTHERWISE SPECIFIED

STAMPED WITH TRIANGLE
NAME STAMP

CHANGE LEVEL
F 12-11-03