

HF 4216P

CUSTOMER REFERENCE NOTE: The recommended tolerance for the diameter of the mounting hole into which the ball bushing (F) is pressed is +0.000", -0.001". The press fit will increase with a decrease in hole diameter. Freedom of movement of the spherical bushing in it's retainer may decrease as the press fit increases.

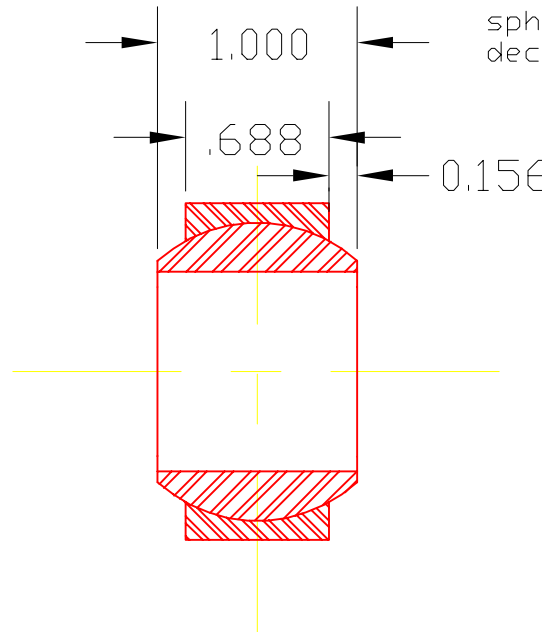

MAXIMUM ROTATION

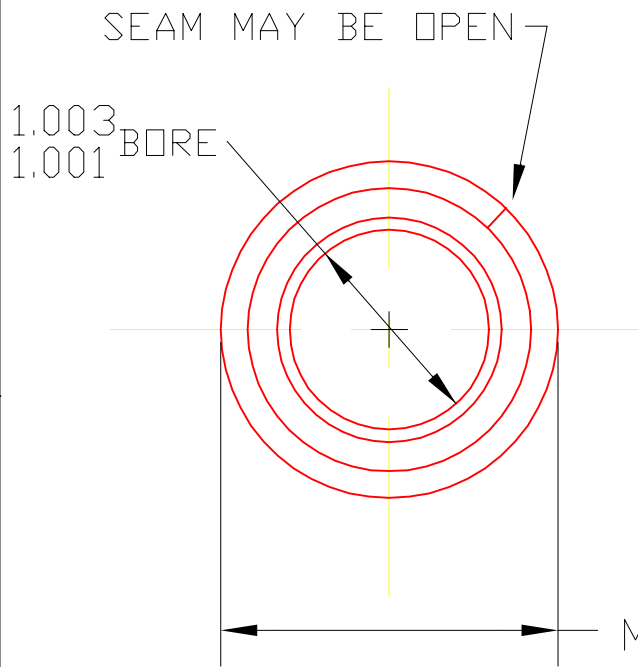
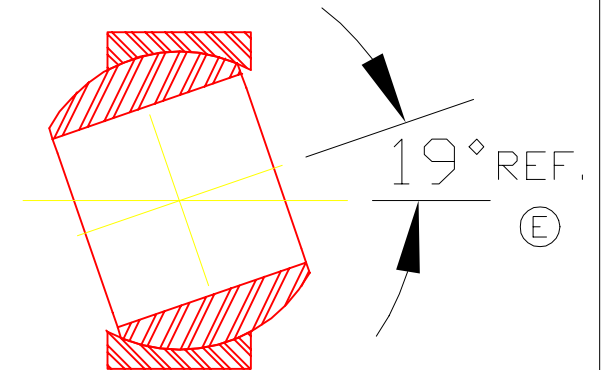

MINIMUM OF (200 LBS.)  
PRESS FIT IN 1.6875  
DIA. HOLE.

2	4216P	BRG. BALL	1
1	4012	RETAINER	1
DET	PART NUMBER	DESCRIPTION	AMT

△ TRIANGLE MANUFACTURING CO.  
OSHKOSH, WI.

NAME BALL & RET. ASS'Y

USED IN HF SERIES

DATE 1-21-70

PART NO.

DRAWN SP

CHECKED SP

SCALE 1 / 1

HF 4216P

(B) (A) FIT LIGHT DRAG - SNUG

PLATING ZINC

MATERIAL SEE DETAILS

ALL DIMS ±.02 UNLESS SPECIFIED

STAMPED WITH TRIANGLE  
NAME STAMP

CHANGE LEVEL	
F	12-11-03